

# ROCK INJECTOR POINT

HP - 80500 - 14"

## Dimensions

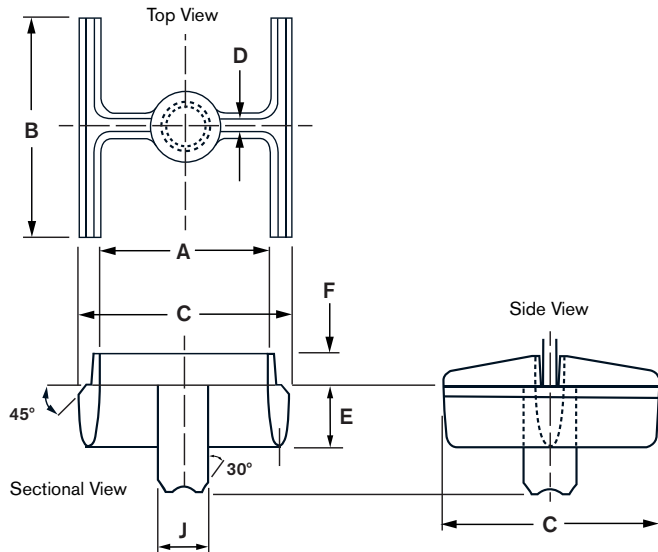

**MATERIAL: CAST STEEL**  
 ASTM A148 90/60  
 Weight 70#

	14"
A	11 3/4"
B	14 1/4"
C	14 1/2"
D	1 3/4"
E	4"
F	4"
J	3 1/2"

NORMAL FOUNDRY TOLERANCES APPLY

## Attachment Procedures

1. Fit point onto the end of the square cut pile end.
2. Weld point to the pile in either flat or vertical position using E70XX electrodes.
3. Weld across full width of flange following chart below for minimum size weld.

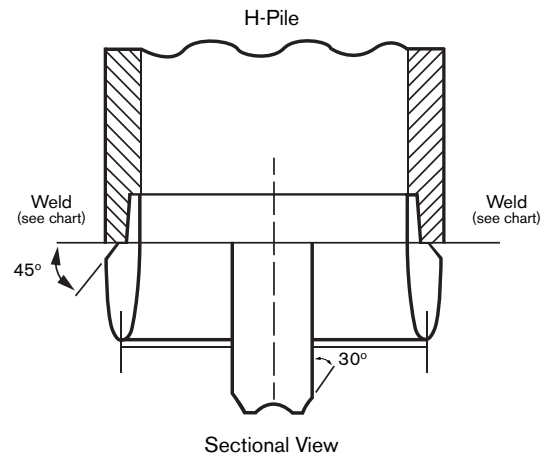

Pile Size	Flange Thickness	Groove Weld
HP 14 x 117	.805	7/16
x 102	.705	3/8
x 89	.615	3/8
x 73	.505	5/16



**ASSOCIATED PILE  
& FITTING**

45 Samworth Road, Clifton, NJ 07014  
 Tel: 973-773-8400  
 Fax: 973-773-8442  
 email: apf@associatedpile.com  
 www.associatedpile.com  
 Call Toll Free: 800-526-9047