

# DRIVE FIT SPLICER SLEEVE

## S - 20000

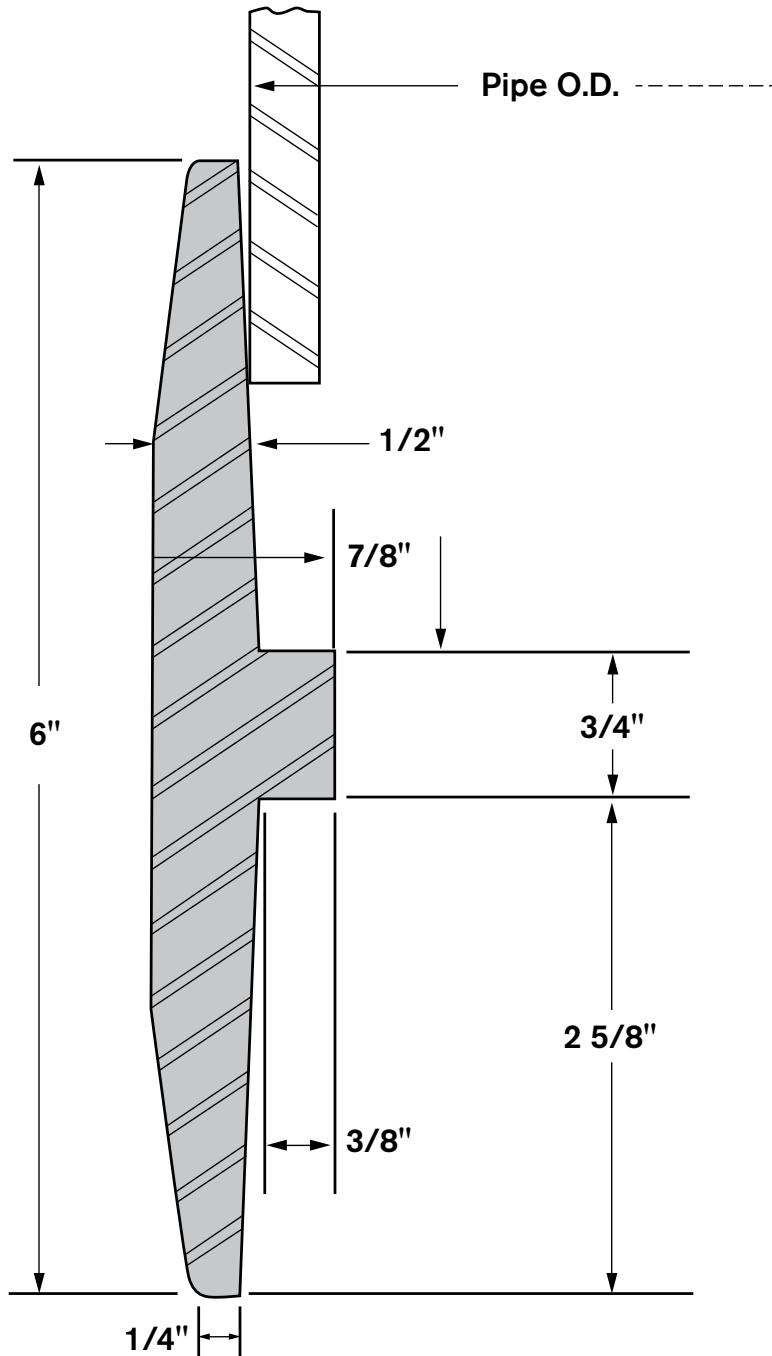

**MATERIAL: CAST STEEL**

ASTM A148 90/60

PIPE O.D.	WEIGHT
7 5/8"	23#
8 5/8"	19#
9 5/8"	31#
10 3/4"	28#
12"	31#
12 3/4"	31#

SECTION THROUGH PIPE AND SPLICER.  
NORMAL FOUNDRY TOLERANCES APPLY.

### ***Installation Instructions***

1. Set the splicer on the driven length of pipe. Tap the splicer onto the pipe with a sledge hammer to secure in place.
2. Set the second length of pipe into the splicer.
3. Seating the two lengths of pipe onto the centering ledge of the splicer will require one or two blows of the hammer. The piles must be seated on the centering ledge prior to driving.
4. Once the pipe piles are seated, continue to drive the pile.



**ASSOCIATED PILE  
& FITTING**

45 Samworth Road, Clifton, NJ 07014

Tel: 973-773-8400

Fax: 973-773-8442

email: [apf@associatedpile.com](mailto:apf@associatedpile.com)

[www.associatedpile.com](http://www.associatedpile.com)

Call Toll Free: 800-526-9047

# DRIVE FIT SPLICER SLEEVE

S - 20000 - 13-3/8"

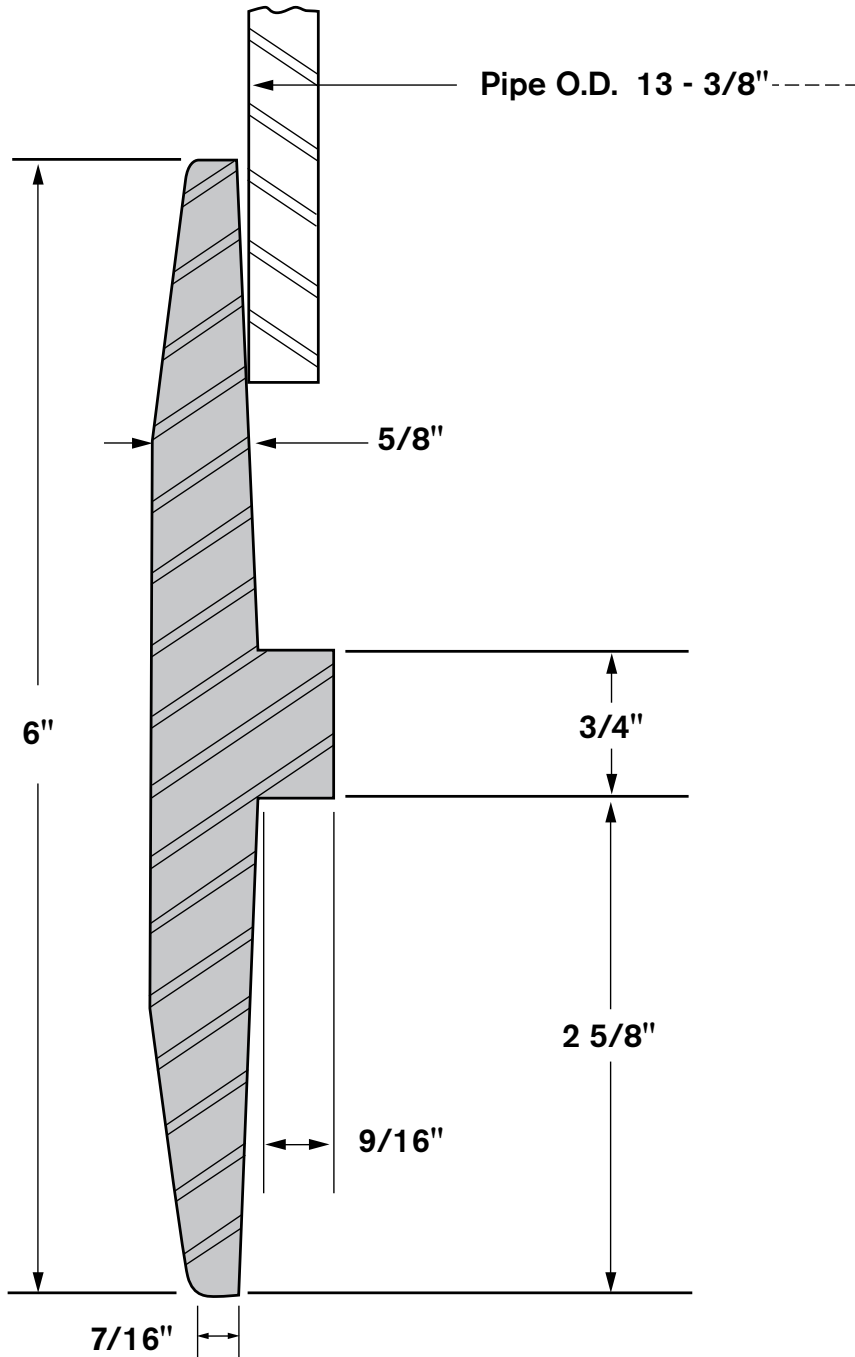

## MATERIAL: CAST STEEL

ASTM A148 90/60

Weight: 51#

SECTION THROUGH PIPE AND SPLICER.  
NORMAL FOUNDRY TOLERANCES APPLY.

## Installation Instructions

1. Set the splicer on the driven length of pipe. Tap the splicer onto the pipe with a sledge hammer to secure in place.
2. Set the second length of pipe into the splicer.
3. Seating the two lengths of pipe onto the centering ledge of the splicer will require one or two blows of the hammer. The piles must be seated on the centering ledge prior to driving.
4. Once the pipe piles are seated, continue to drive the pile.



**ASSOCIATED PILE  
& FITTING**

45 Samworth Road, Clifton, NJ 07014

Tel: 973-773-8400

Fax: 973-773-8442

email: [apf@associatedpile.com](mailto:apf@associatedpile.com)

[www.associatedpile.com](http://www.associatedpile.com)

Call Toll Free: 800-526-9047

# DRIVE FIT SPLICER SLEEVE

S - 20000 - 13-5/8"

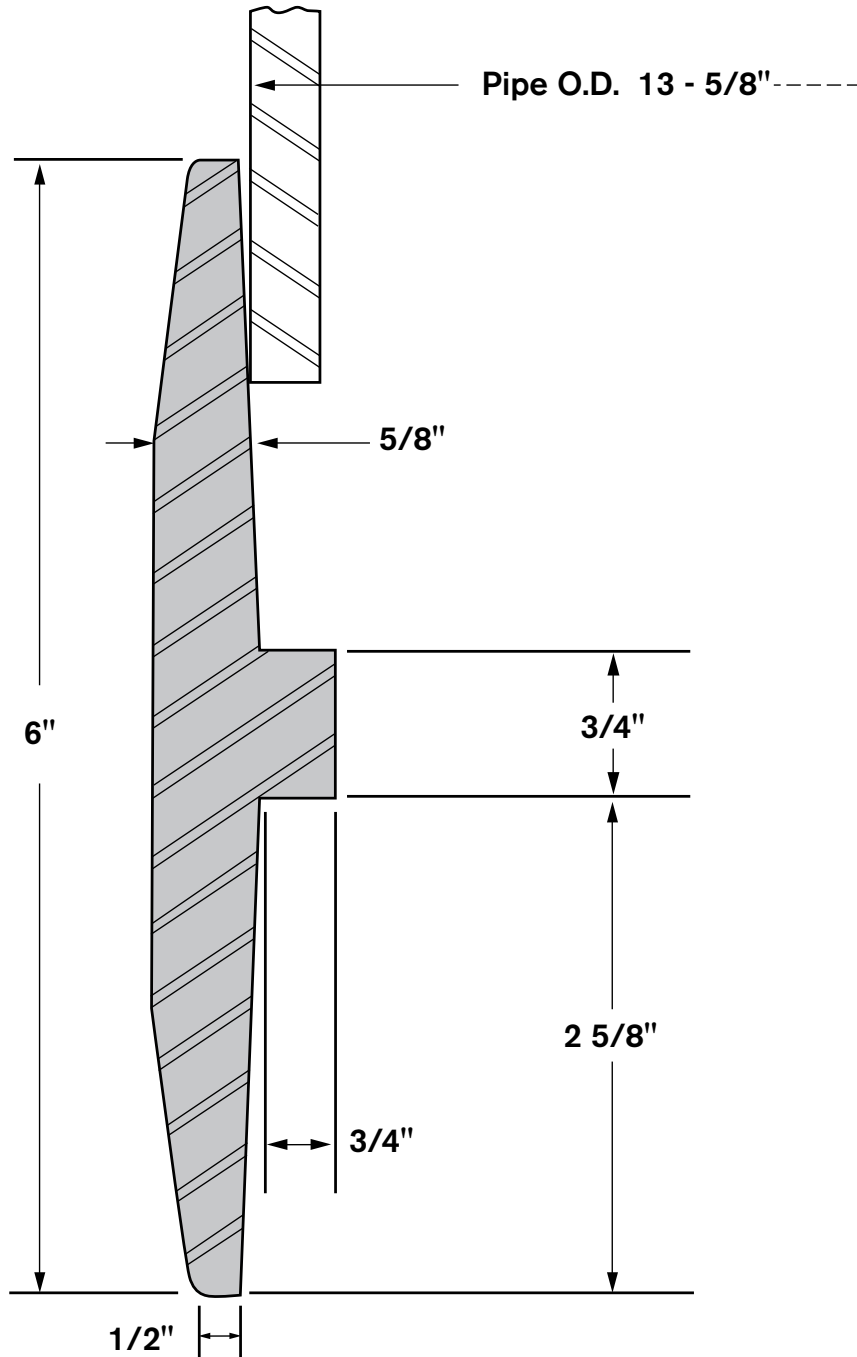

## MATERIAL: CAST STEEL

ASTM A148 90/60

Weight: 51#

SECTION THROUGH PIPE AND SPLICER.  
NORMAL FOUNDRY TOLERANCES APPLY.

## Installation Instructions

1. Set the splicer on the driven length of pipe. Tap the splicer onto the pipe with a sledge hammer to secure in place.
2. Set the second length of pipe into the splicer.
3. Seating the two lengths of pipe onto the centering ledge of the splicer will require one or two blows of the hammer. The piles must be seated on the centering ledge prior to driving.
4. Once the pipe piles are seated, continue to drive the pile.



**ASSOCIATED PILE  
& FITTING**

45 Samworth Road, Clifton, NJ 07014

Tel: 973-773-8400

Fax: 973-773-8442

email: [apf@associatedpile.com](mailto:apf@associatedpile.com)

[www.associatedpile.com](http://www.associatedpile.com)

Call Toll Free: 800-526-9047

# DRIVE FIT SPLICER SLEEVE

S - 20000 - 14" & 16"

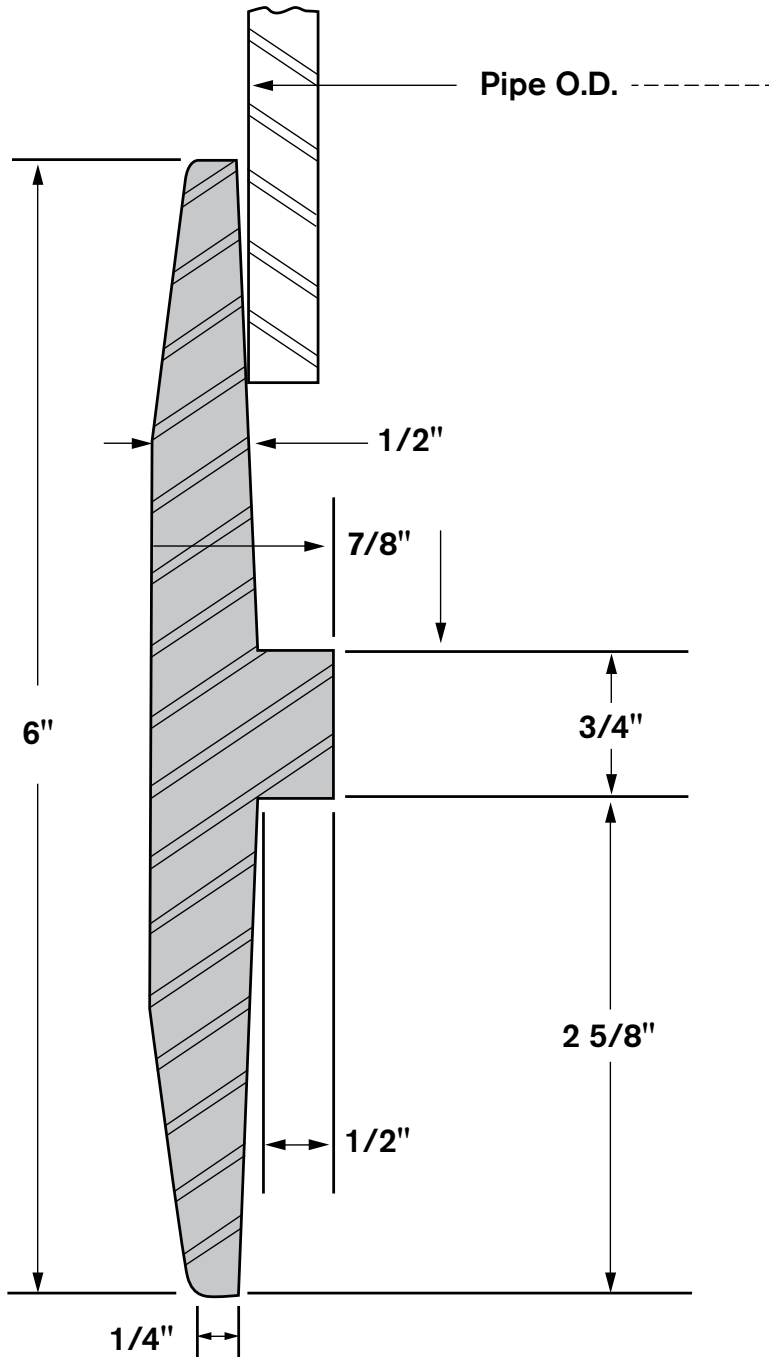

**MATERIAL: CAST STEEL**

ASTM A148 90/60

PIPE O.D.	WEIGHT
14"	39#
16"	42#

SECTION THROUGH PIPE AND SPLICER BEFORE DRIVING.

NORMAL FOUNDRY TOLERANCES APPLY.

### **Installation Instructions**

1. Set the splicer on the driven length of pipe. Tap the splicer onto the pipe with a sledge hammer to secure in place.
2. Set the second length of pipe into the splicer.
3. Seating the two lengths of pipe onto the centering ledge of the splicer will require one or two blows of the hammer. The piles must be seated on the centering ledge prior to driving.
4. Once the pipe piles are seated, continue to drive the pile.



**ASSOCIATED PILE  
& FITTING**

45 Samworth Road, Clifton, NJ 07014

Tel: 973-773-8400

Fax: 973-773-8442

email: [apf@associatedpile.com](mailto:apf@associatedpile.com)

[www.associatedpile.com](http://www.associatedpile.com)

Call Toll Free: 800-526-9047

# DRIVE FIT SPLICER SLEEVE

S - 20000 - 18"

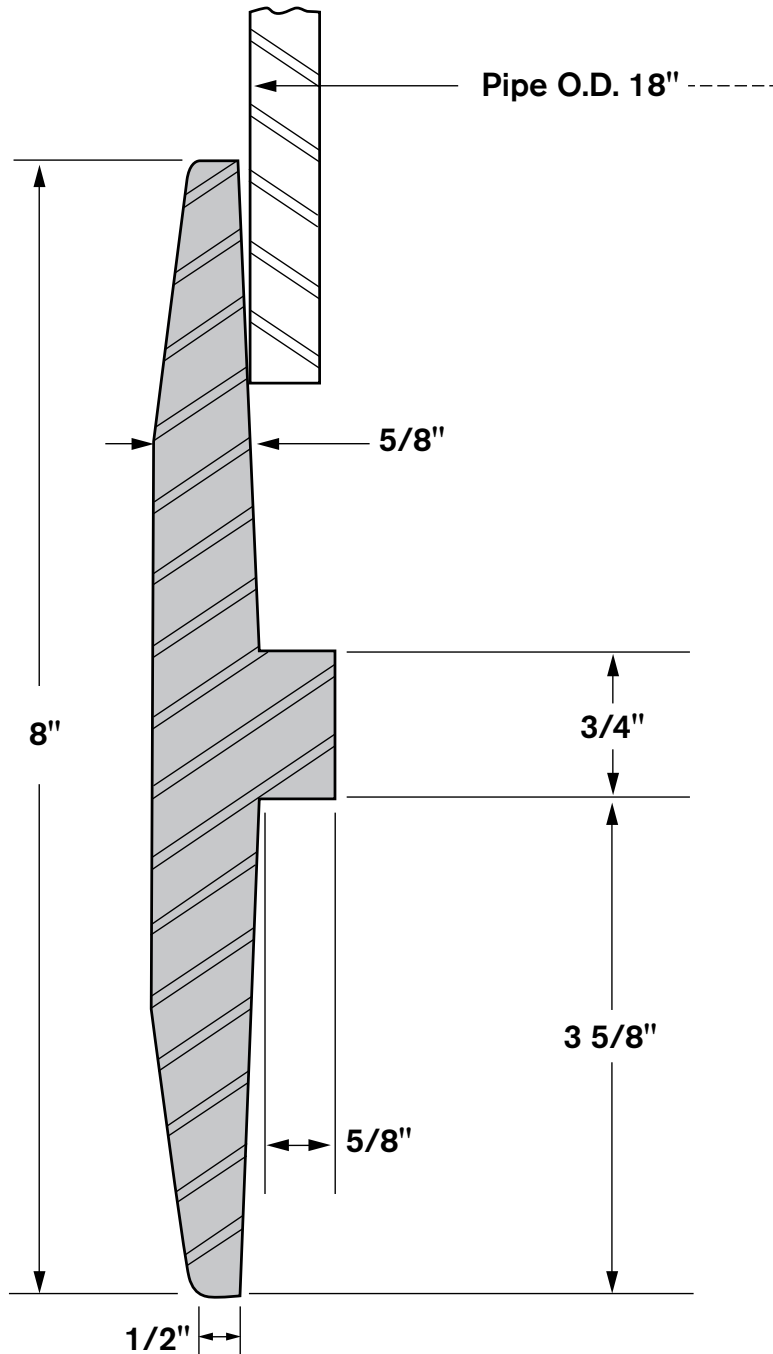

## MATERIAL: CAST STEEL

ASTM A148 90/60

Weight: 95#

SECTION THROUGH PIPE AND SPLICER.  
NORMAL FOUNDRY TOLERANCES APPLY.

## Installation Instructions

1. Set the splicer on the driven length of pipe. Tap the splicer onto the pipe with a sledge hammer to secure in place.
2. Set the second length of pipe into the splicer.
3. Seating the two lengths of pipe onto the centering ledge of the splicer will require one or two blows of the hammer. The piles must be seated on the centering ledge prior to driving.
4. Once the pipe piles are seated, continue to drive the pile.



**ASSOCIATED PILE  
& FITTING**

45 Samworth Road, Clifton, NJ 07014

Tel: 973-773-8400

Fax: 973-773-8442

email: [apf@associatedpile.com](mailto:apf@associatedpile.com)

[www.associatedpile.com](http://www.associatedpile.com)

Call Toll Free: 800-526-9047

# DRIVE FIT SPLICER SLEEVE

S - 20000 - 20"

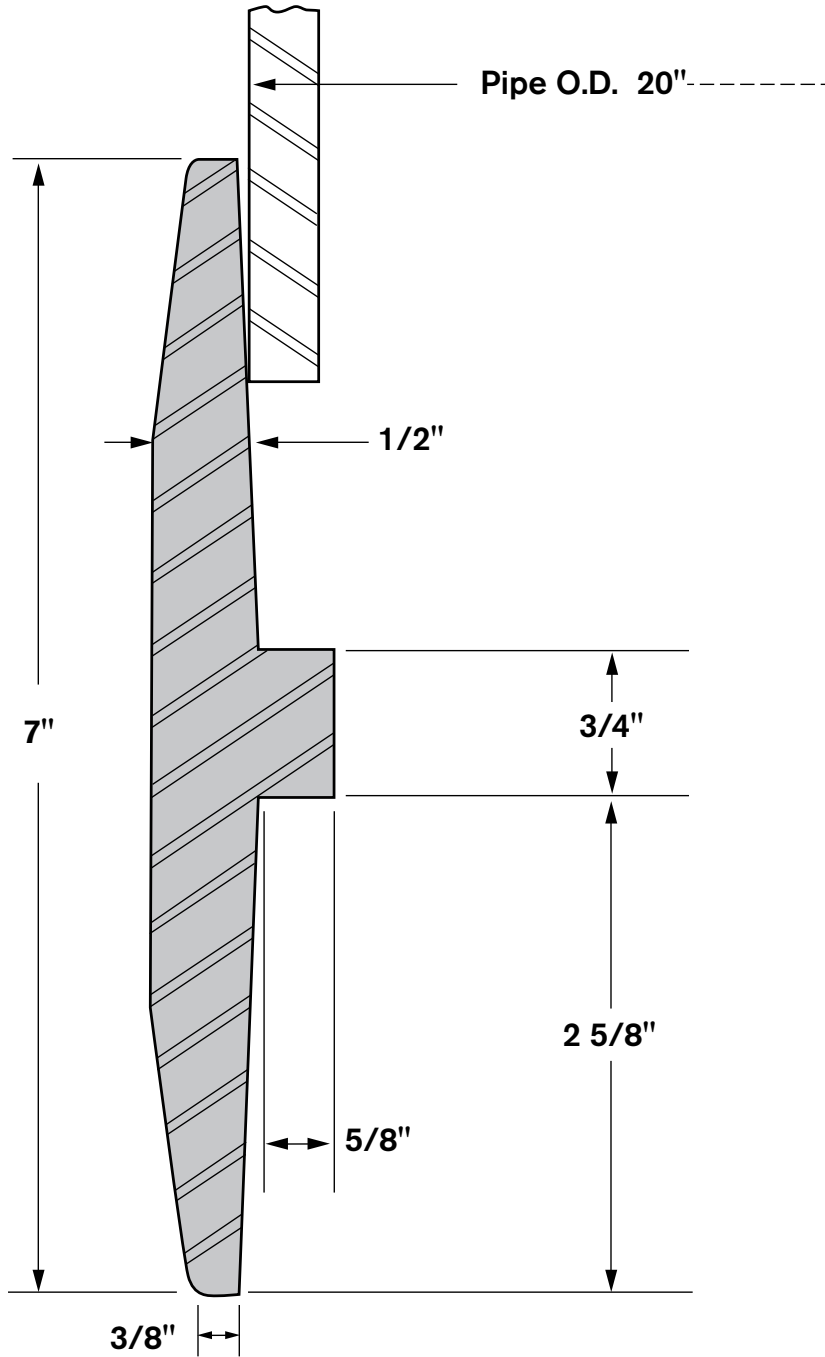

## MATERIAL: CAST STEEL

ASTM A148 80/50

Weight: 89#

SECTION THROUGH PIPE AND SPLICER.  
NORMAL FOUNDRY TOLERANCES APPLY.

## Installation Instructions

1. Set the splicer on the driven length of pipe. Tap the splicer onto the pipe with a sledge hammer to secure in place.
2. Set the second length of pipe into the splicer.
3. Seating the two lengths of pipe onto the centering ledge of the splicer will require one or two blows of the hammer. The piles must be seated on the centering ledge prior to driving.
4. Once the pipe piles are seated, continue to drive the pile.



**ASSOCIATED PILE  
& FITTING**

45 Samworth Road, Clifton, NJ 07014

Tel: 973-773-8400

Fax: 973-773-8442

email: [apf@associatedpile.com](mailto:apf@associatedpile.com)

[www.associatedpile.com](http://www.associatedpile.com)

Call Toll Free: 800-526-9047

# DRIVE FIT SPLICER SLEEVE

S - 20000 - 24"

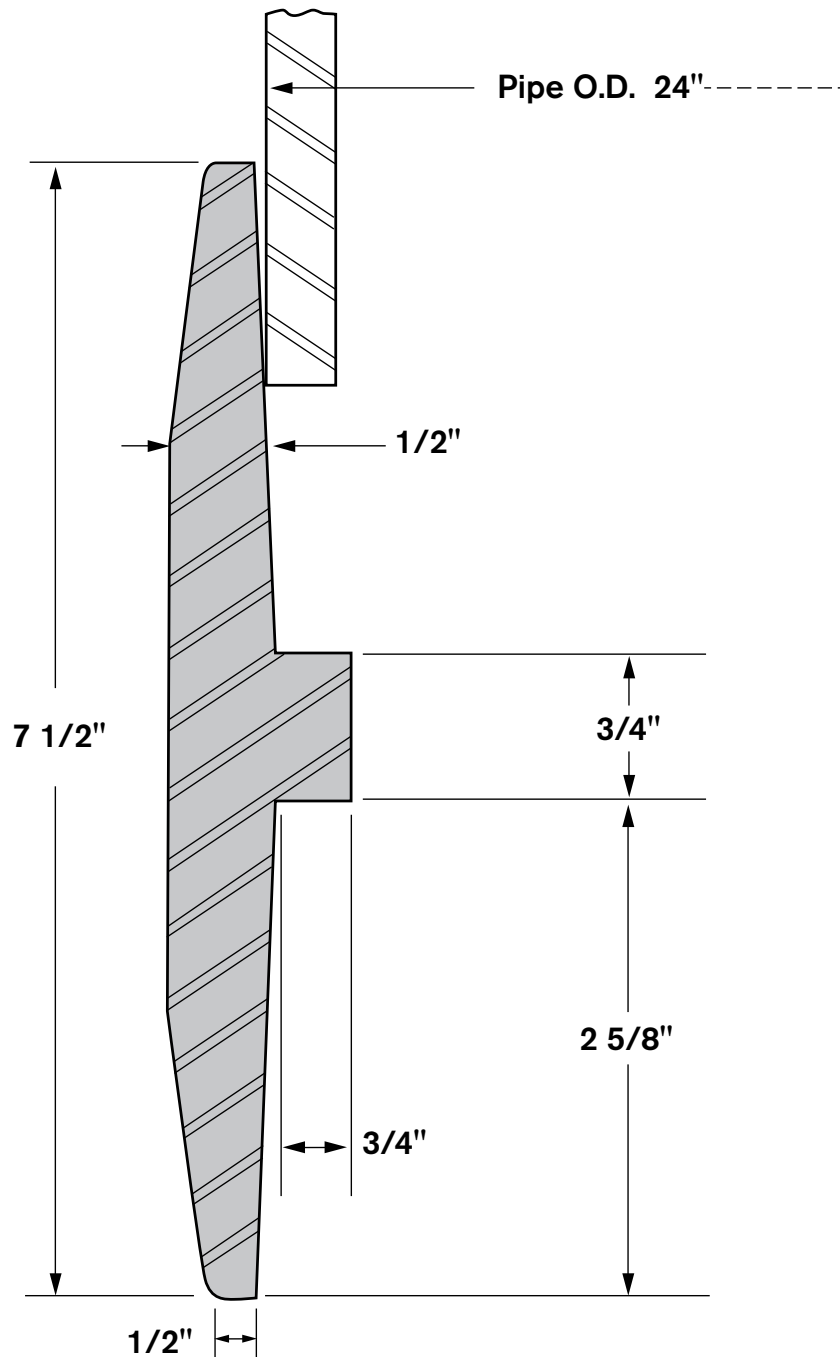

## MATERIAL: CAST STEEL

ASTM A148 80/50

Weight: 96#

SECTION THROUGH PIPE AND SPLICER.  
NORMAL FOUNDRY TOLERANCES APPLY.

## Installation Instructions

1. Set the splicer on the driven length of pipe. Tap the splicer onto the pipe with a sledge hammer to secure in place.
2. Set the second length of pipe into the splicer.
3. Seating the two lengths of pipe onto the centering ledge of the splicer will require one or two blows of the hammer. The piles must be seated on the centering ledge prior to driving.
4. Once the pipe piles are seated, continue to drive the pile.



**ASSOCIATED PILE  
& FITTING**

45 Samworth Road, Clifton, NJ 07014

Tel: 973-773-8400

Fax: 973-773-8442

email: [apf@associatedpile.com](mailto:apf@associatedpile.com)

[www.associatedpile.com](http://www.associatedpile.com)

Call Toll Free: 800-526-9047