

CONICAL POINT

Model VB9

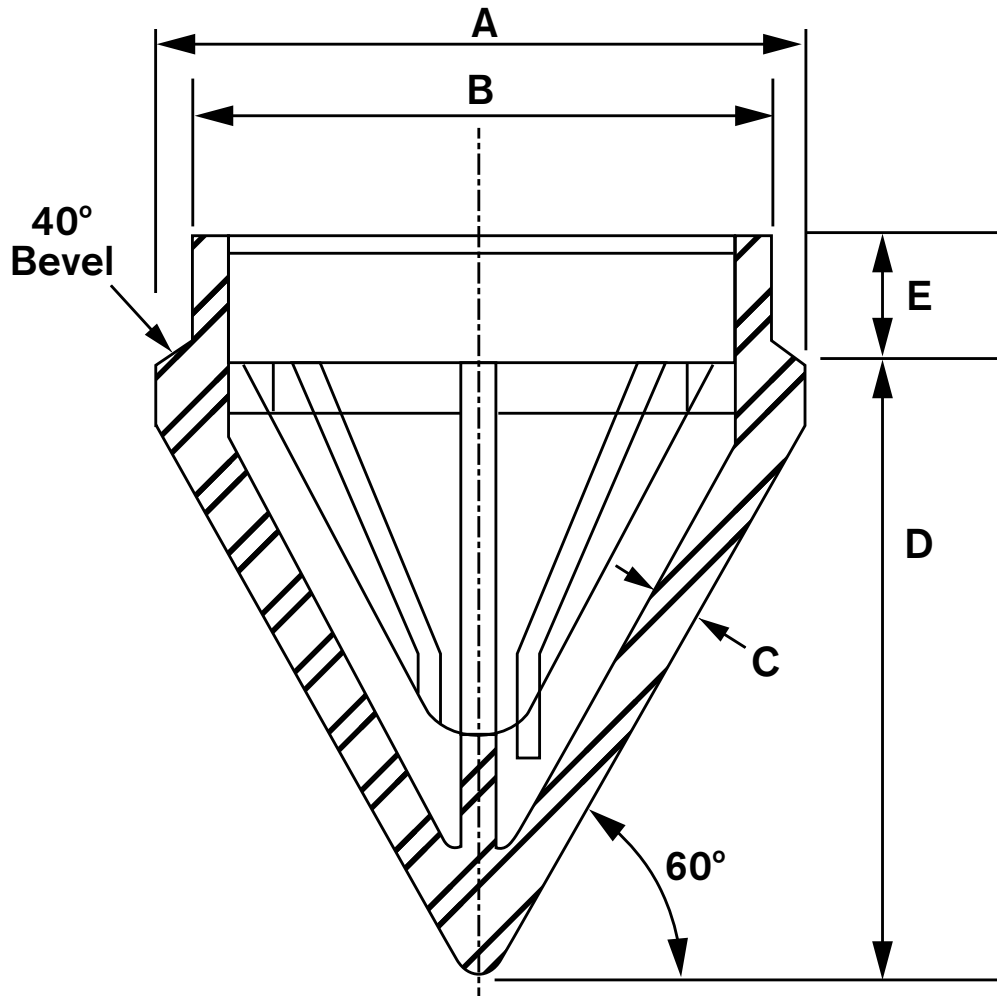

MATERIAL: CAST STEEL

ASTM A148 80/50

NORMAL FOUNDRY TOLERANCES APPLY

Installation Instructions

1. Hold conical point in close contact with the end of a square cut pile.
2. Place a 5/16" partial penetration single-bevel groove weld along the entire circumference of the pile/shoe interface utilizing an E70XX low hydrogen electrode or equivalent filler material.

Note: Place a 3/8" bevel at 40 degrees on the pipe if the point is not pre-beveled. AWS standard tolerances for bevel angle and root face apply.

PIPE OD	A	B	C	D	E	wt
30"	30"	27-3/4"	3/4"	28"	1"	410#



**ASSOCIATED PILE
& FITTING**

45 Samworth Road, Clifton, NJ 07014

Tel: 973-773-8400

Fax: 973-773-8442

email: apf@associatedpile.com

www.associatedpile.com

Call Toll Free: 800-526-9047