

# LARSEN 45

## Steel Sheet Pile Connector

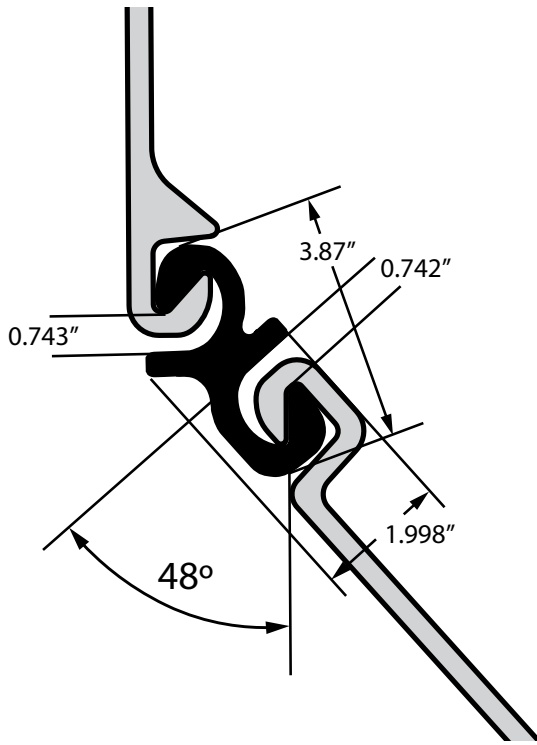

ASTM A572 Gr. 50  
9.88 lb/ft

- Designed for use in Larsen Interlock Applications
- Can Be Used in 6 Different Orientations

#### ATTACHMENT PROCEDURE

1. Thread connector into interlock of sheet pile.
2. Tack weld connector to pile.

#### Orientations

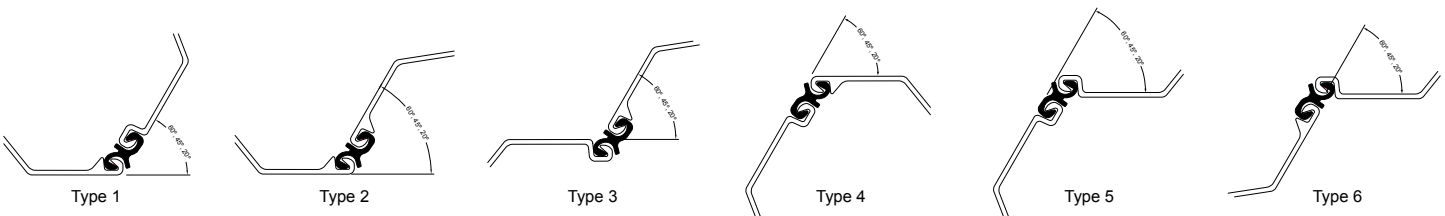

**ASSOCIATED PILE  
& FITTING**

45 Samworth Road, Clifton, NJ 07014  
 Tel: 973-773-8400  
 Fax: 973-773-8442  
 email: [apf@associatedpile.com](mailto:apf@associatedpile.com)  
[www.associatedpile.com](http://www.associatedpile.com)  
 Call Toll Free: 800-526-9047